

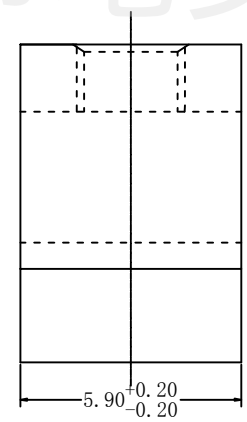

东莞市地安电子科技有限公司
DONGGUAN CITY DIERAN ELECTRONICS CO.,LTD

REVISION RECORD				
REV.	DESCRIPTION	ECN NO.	APPROVED	DATE

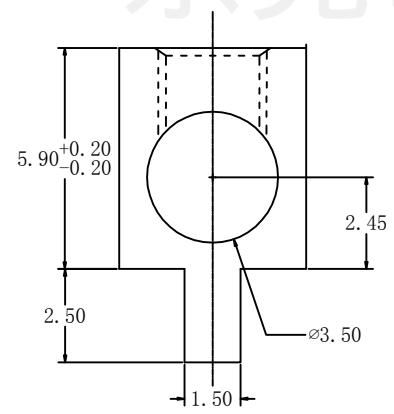
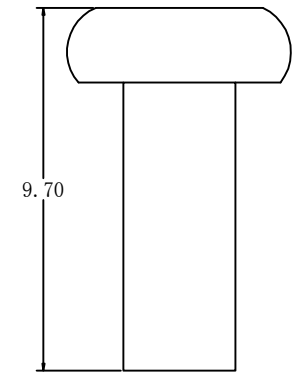
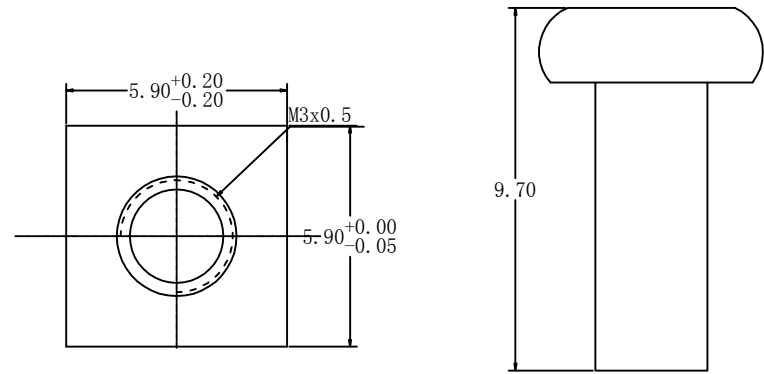

项目/参数	
额定电压 (Rated Voltage) [V]	300
额定电流 (Rated Current) [A]	12
额定线经平方 (Wire Range mm ²)	0.2-4
额定线经线号 (Wire Range AWG)	24-12
冲击电压 Impulse withstand voltage	2 (KV)
剥线长度 (Stripping Length) [mm]	5-6 (mm)
螺丝/扭矩 (Screw Torque Max)	M3/0.5 (N.m)
导体材料 (Contactor Material)	黄铜 (Brass)
导体表面镀层 (Contactive Coating)	镀锡 (Dumb tin)
工作温度 (Operating temperatur) [°C]	-40°C ~ +105°C
焊锡温度 (Soldering temperature) [°C]	250°C / 5S

东莞市地安电子科技有限公司

linear dimension (Tolerances Standard GB/T 14486-2008)										
variable range	to	over 6 to	over 10 to	over 30 to	over 60 to	over 100 to	over 160 to	to 10	to 100	to 100
tolerance	±0.20	±0.30	±0.50	±0.70	±1.00	±1.30	±1.60	0.10	0.30	0.60

单位/UNITS	mm	尺寸/SIZE	A4	比例/SCALE	1:1	第三视角/THIRD ANGLE PROJECTION	版本/REV	V0
东莞市地安电子科技有限公司						名称/TITLE	6x6x6	